

# PRESSES

## H-FRAME 150-200 TONS

Simplex Monster Press Used In Rail Car Maintenance.



- Remote control.
- Fast double-acting hydraulics.
- Large daylight with open sides for easy loading.
- Moveable work head for maximum versatility.
- Adjustable work bed with friction brake winch.
- Heavy duty pin & welded construction frame.
- Rigid frame under full load.
- Includes Tonnage Gauge.
- IED Series comes with pendant control.

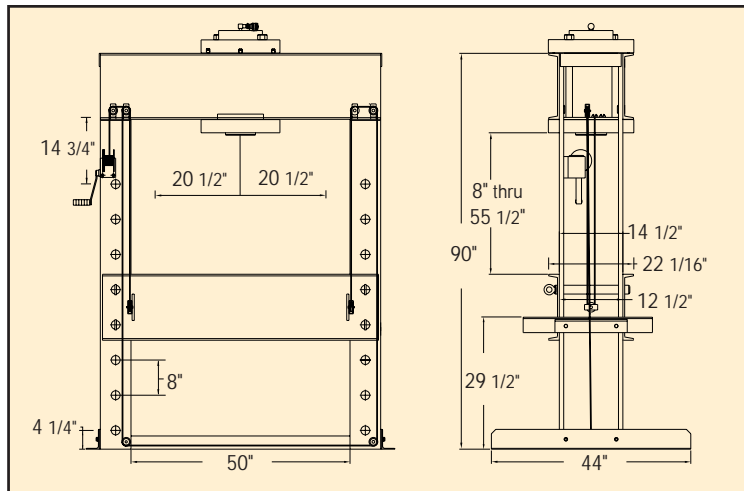

Rail car repair shops are constantly faced with large jobs, reforming rail car components, installing and removing bolster parts and straightening or bending under-carriage assemblies. These applications require a reliable and safe high tonnage press. "The Simplex Monster Press gave us just what we were looking for, a large work area and easy operation."

*Presses ordered with pumps include remote pendant control and large 5 gallon reservoir. The pump is floor mounted.*

### 150 & 200 Ton H-Frame Press

Model Number Without Pump	Model Number With Pump	Type of Cylinder	Cylinder Stroke (in)	Type of Pump	Pump Model	Operation	Speed (in/min)		Weight With Pump (lbs)	Weight Without Pump (lbs)
							Advance	Pressing		
ID15012	IED15012	RDA15012 D/A	12	Electric Powered	PES6045	Advance, Hold	20	4.5	3035	2839
ID20013	IED20013	RDA20013 D/A	13		230 3 Ph.	Retract	14	3.5	3180	2984

■ Custom Build Your Press by ordering models without pumps. Order separately any Simplex pump and pump mounting kit that meet your requirements, and you're ready for operation.