

H-FRAME - 25 & 30 TONS

PRESSES

Simplex 25 Ton Press Reduces Production Line Down Time.



- Large daylight with open sides for easy loading.
- Heavy duty welded construction.
- Rigid frame under full load.
- Moveable work head for maximum versatility.
- Adjustable work bed with friction brake winch.
- Wide choice of pumps & pressing cylinders.
- Includes tonnage gauge.
- IED & IES Series comes with pendant control.

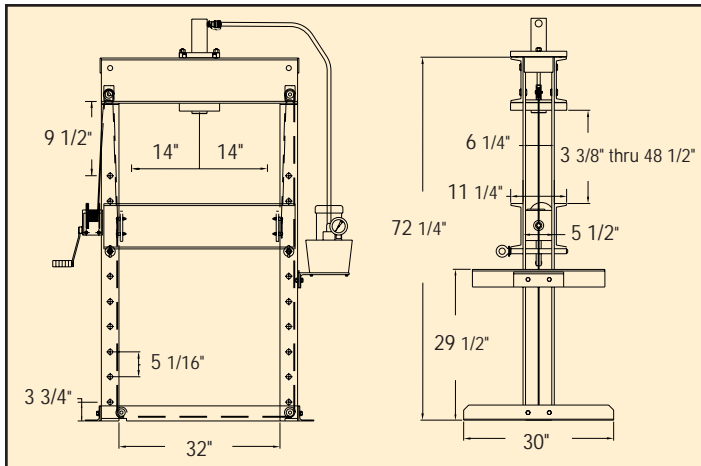

A manufacturer of industrial gear boxes used the Simplex 25 ton press in their production assembly line to press various size bearings on gear assemblies. "We can press up to 100 bearings an hour with the Simplex press. The hydraulics are reliable and easy to use and they keep working day after day."

Pump Mounting Kit	
For Hand Pumps:	Model IM2
For Power Pumps:	Model IM3
See Page 90	
Cylinder Mounting Kit	
Single-Acting:	Model MC25
(Included with Press)	
See Page 90	

25 and 30 Ton H-Frame Press

Model Number Without Pump	Model Number With Pump	Type of Cylinder	Cylinder Stroke (in)	Type of Pump	Pump Model	Operation	Speed (in/min)		Weight With Pump (lbs)	Weight Without Pump (lbs)
							Advance	Pressing		
IS256 IS2514	IAS256 IAS2514	R256/ R2514	6	Air Powered	PA91	Advance Hold Retract	14	2	417	----
	Single Acting	6	419							
ID3014	IES256 IES2514	25 Ton Capacity	14	Electric Powered	PEM1021		50	4	435	403
	Single Acting	6	.5*				.05*	423	439	----
ID3014	IMS256 IMS2514	25 Ton Capacity	14	Manual Powered	P82		40	3	462	428
	Single Acting	6	.5*				.05*	458		
ID3014	IED3014 IMD3014	RDA3014	14	Electric Manual	PES4042 P140D	40	3	462	428	
	Single Acting	6	.5*			.05*	458			

* Inches Per Stroke.

■ Custom Build Your Press by ordering models without pumps. For foot or pendant control, higher pressing speeds or optional pump motors order separately the Simplex pump and pump mounting kit that meet your requirements, and you're ready for operation.