

# PRESSES

## H-FRAME - 55 TONS

Simplex 55 Ton Press Handles Hundreds Of Different Jobs At Industrial Repair Shops.



- Large daylight with open sides for easy loading.
- Heavy duty construction.
- Rigid frame under full load.
- Moveable work head for maximum versatility.
- Adjustable work bed with friction brake winch.
- Wide choice of pumps & pressing cylinders.
- Choose double-acting presses for fast retraction.
- Includes tonnage gauge.
- IED & IES Series comes with pendant control.



Repair personnel were faced with a variety of difficult bending, pressing, straightening and disassembly jobs. "Almost every day we have to remove bearings, straighten cylinder rods, perform wheel repair, and rebuild gear boxes. The 55 ton press is perfect; it's adjustable bed and moveable work head gives us the flexibility to work on a wide variety of jobs."

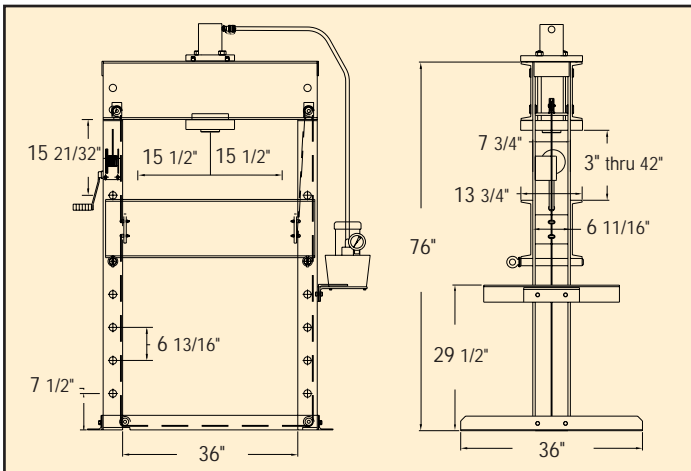

Pump Mounting Kit	
For Hand Pumps:	Model IM2
For Power Pumps:	Model IM3
See Page 90	
Cylinder Mounting Kit	
Single & Double Acting:	
Model MC55	
See Page 90	

### 55 Ton H-Frame Press

Model Number Without Pump	Model Number With Pump	Type of Cylinder	Cylinder Stroke (in)	Type of Pump	Pump Model	Operation	Speed (in/min)		Weight With Pump (lbs)	Weight Without Pump (lbs)
							Advance	Pressing		
IS556	IES556	R556 S/A	6	Electric Powered	PEM1021	Advance Hold Retract	23	2	707	675
IS5513	IES5513	R5513 S/A	13						735	703
ID556	IED556	RDA556 D/A	6		PES4042		35	5	748	710
ID5512	IED5512	RDA5512 D/A	12						793	755
	IMS556	R556 S/A	6	Manual	P82	.25*	.02*	711	----	

\* Inches Per Stroke.

■ Custom Build Your Press by ordering models without pumps. For foot or pendant control, higher pressing speeds or optional pump motors order separately the Simplex pump and pump mounting kit that meet your requirements, and you're ready for operation.