

B50 - 50 TON

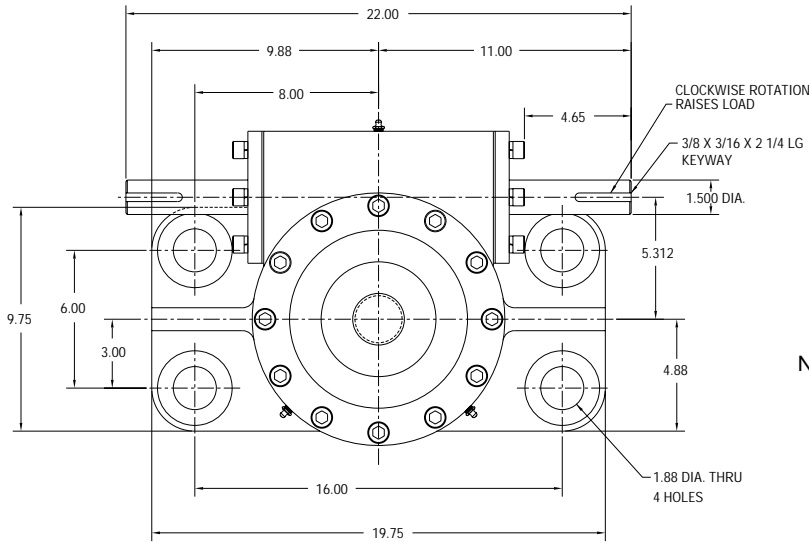

REF.	GEAR RATIO	TURNS /INCH	TORQUE REQUIRED TO LIFT 1 LB (lb-in)
L	10.66:1	10 2/3	0.025
H	32:1	32	0.014
RATED CAPACITY			100,000 lbs.
Max Input Speed			1200 rpm
Max Screw Stock			215 in.
Load Screw			4 in. dia. x 1 in. lead
Stop Nut Allowance			3 in.

NOTES:

1. Load screw or nut must be secured to produce linear travel.
2. Dimensions are for reference only and will change with the addition of boots, attachments, and accessories.
3. Boots and boot adaptors are available. (Pages 74-75)
4. Travel must be adjusted to allow for mounting structure on inverted actuators.
5. Customer is responsible for providing positive stops at ends of travel.
6. **CAUTION: BALL SCREW JACKS ARE NON-LOCKING, BRAKES MUST BE USED TO HOLD SCREW IN POSITION.**

TRANSLATING & KEYED

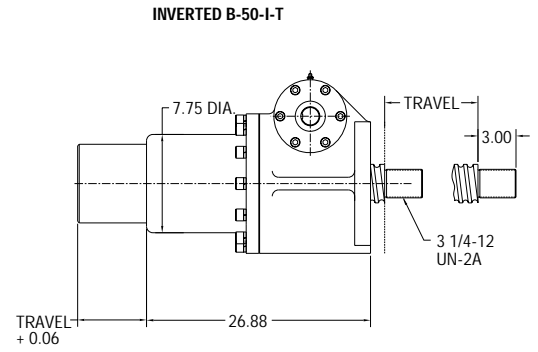
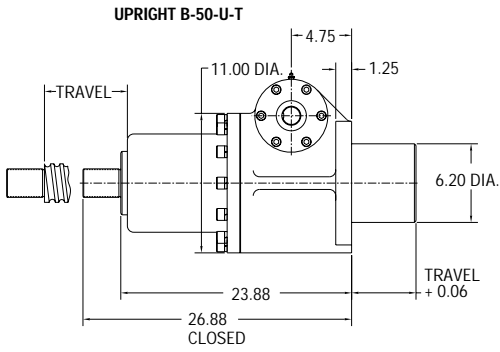

TOP PLATE AND CLEVIS END OPTIONS

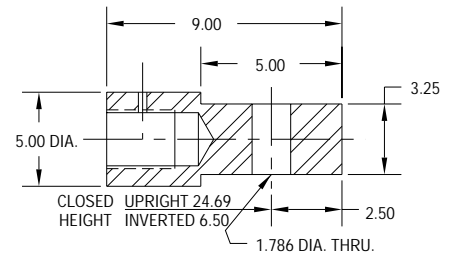
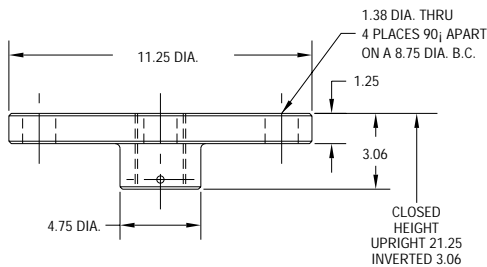

ROTATING WITH TRAVELING NUT

