

POWER PUMPS

AIR POWERED HYDRAULIC PUMPS

The Simplex Air Hydraulic pumps Are The Toughest, Most Reliable In The Field.

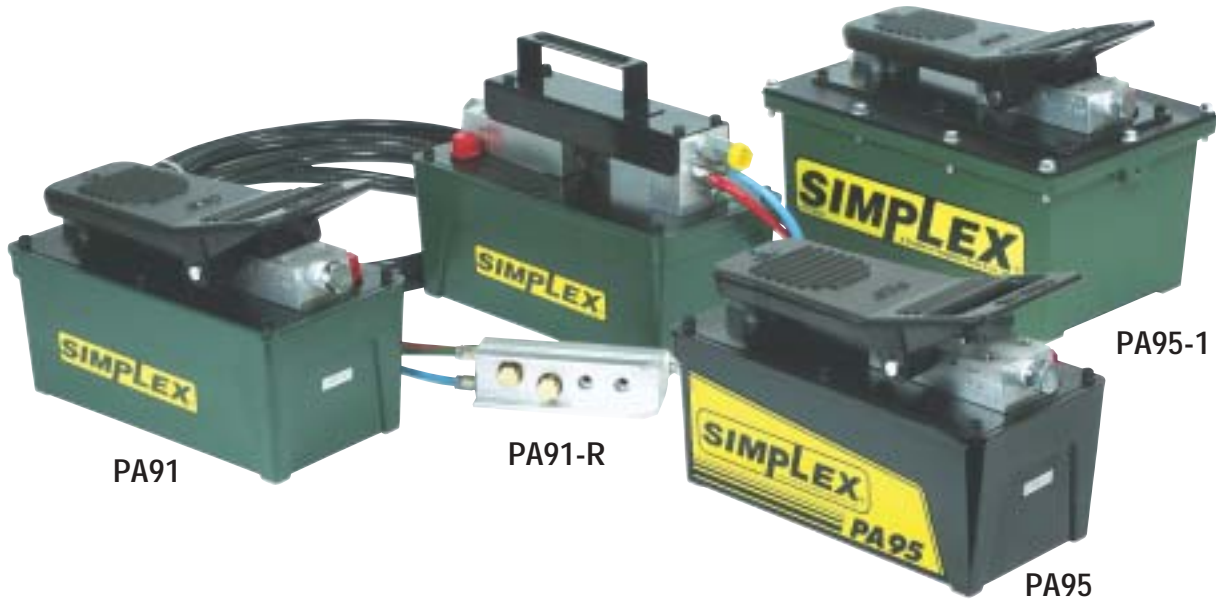

Easy Operation with Hand or Foot Control

					<p>The PA91D utilizes a 3 position 4 way valve for use with double acting tools.</p>
Hydraulic Cylinders pgs. 11-30	Presses Pgs. 89-96	Hoses pgs. 70-71	Accessories & Fittings pgs. 68-72		

- PA91 is ideal for most applications and provides exceptional value.
- PA95 provides high performance in a compact, easy to use package.
- Powers a wide variety of single-acting tools.
- PA91D powers a wide variety of double-acting tools.
- Rugged all metal construction.
- High performance/fast operation.
- Pressure relief valve protects hydraulic circuit.
- Reduced noise for in house production.
- Reduced operator fatigue.
- 3 position treadle for advance, hold and retract.
- Uses standard shop air.

PA91 & PA95 Air Over Oil Pump

Model Number	Usable Oil Capacity (cu. in.)	Oil Flow @ 0 psi (cu. in.)	Oil Flow @ 10,000 psi (cu. in.)	Operating Air Pressure Range (psi)	Weight (lbs)
PA91	90	75	6	60 - 150	20
PA91-R					21
PA91-1	230	70	10		28
PA91-1R					29
PA91D	90				19
PA95					20
PA95-1	230			28	

PERFORMANCE CHART

Flow @ 100 psi Air

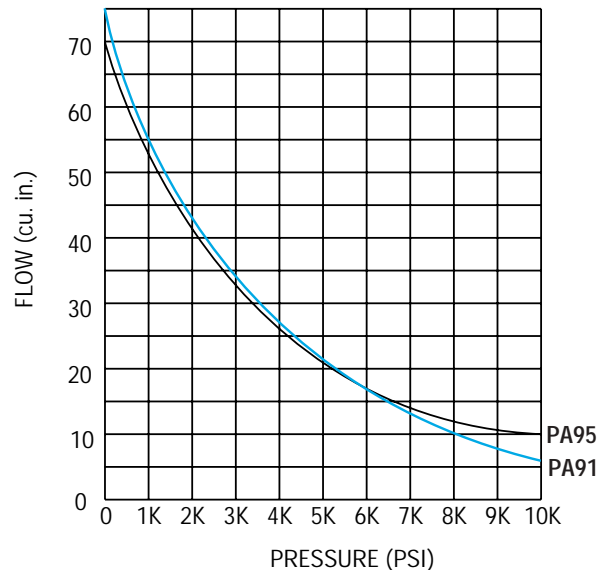

NEW!!

AIR POWERED HYDRAULIC PUMP

POWER PUMPS

PA91 & PA95
90 cu. in. Reservoir

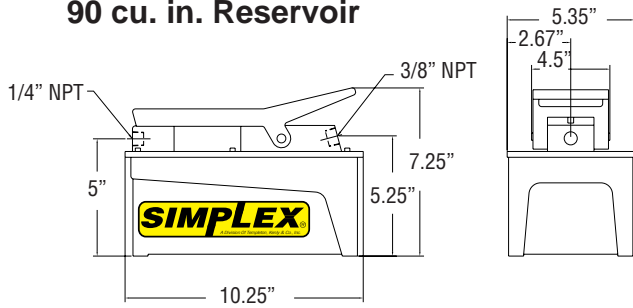

PA91-1 & PA95-1
230 cu. in. Reservoir

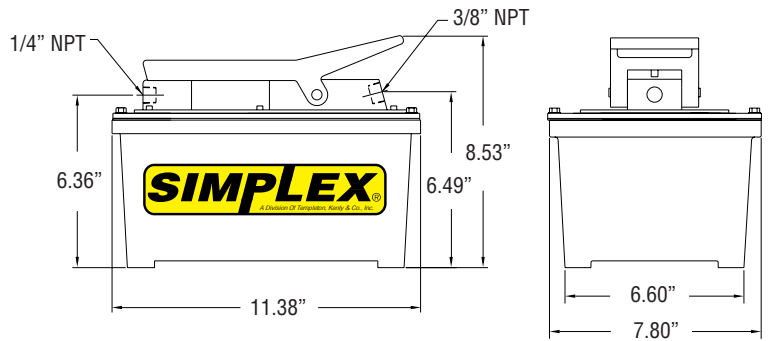

PA91-R
90 cu. in. Reservoir

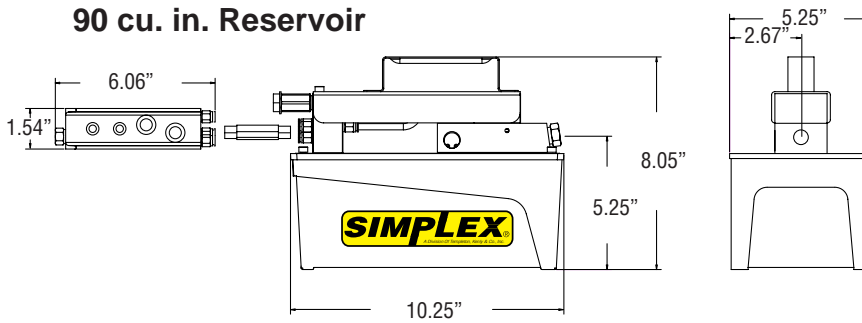

PA91D
90 cu. in. Reservoir

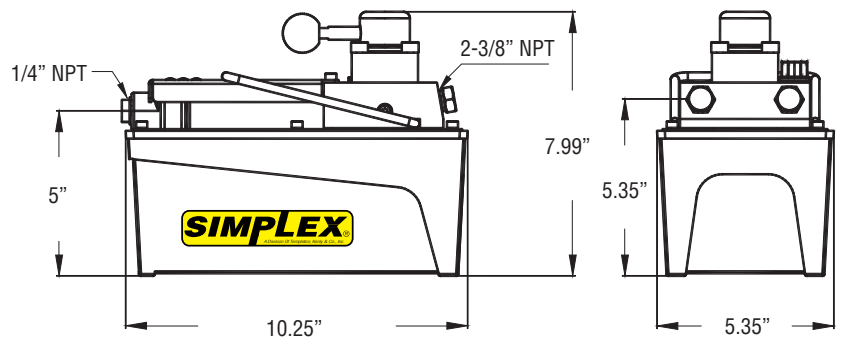

Engineers selected the Simplex air pump when reliable 10,000 psi power was needed to run this production line fixture, industrial engineers chose the Simplex PA91. "The three position treadle is easy to use and the pump runs on standard shop air."