

POWER PUMPS

AIR POWERED HYDRAULIC PUMPS

The Simplex PA91 & PA95 Are The Toughest, Most Reliable Air Hydraulic Pump In The Field.





NEW!!

The PA91R & PA91-1R utilize a hand pendant remote with 12' hose.

Easy Operation with Hand or Foot Control

					
Hydraulic Cylinders pgs. 10-27	Presses Pgs. 87-92	Hydraulic Spreaders Pg. 71	Hoses pgs. 66-67	A233 Filter Lubricator	Accessories & Fittings pgs. 63-68

- PA91 is ideal for most applications and provides exceptional value.
- PA95 provides high performance in a compact, easy to use package
- Powers a wide variety of single-acting tools.
- Rugged all metal construction.
- High performance/fast operation.
- Pressure relief valve protects hydraulic circuit.
- Reduced noise for in house production.
- Reduced operator fatigue.
- 3 position treadle for advance, hold and retract.
- Uses standard shop air.

PERFORMANCE CHART

Flow @6,9 bar Air

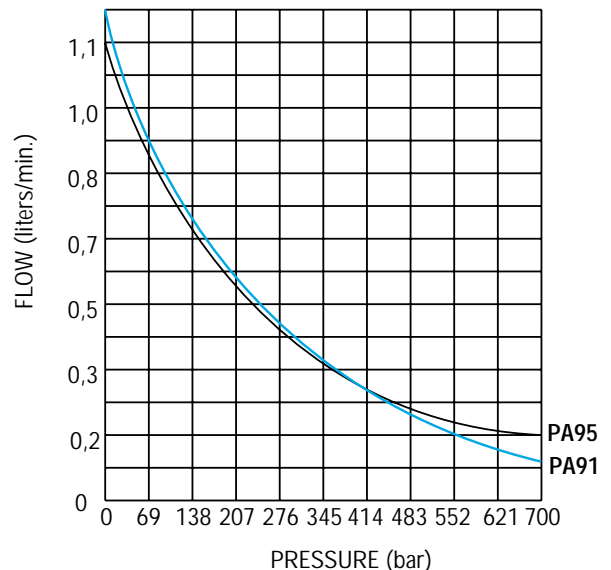

PA91 & PA95 Air Over Oil Pump

Model Number	Usable Oil Capacity (cm ³)	Oil Flow @ 0 bar (liters)	Oil Flow @ 700 bar (liters)	Operating Air Pressure Range (bar)	Weight (kg)
PA91	1475,1	1,2	0,1	4,1 - 10,4	8,4
PA91R					8,7
PA91-1	3769,7				12,7
PA91-1R		13,2			
PA95	1475,1	1,1	0,2		8,4
PA95-1	3769,7				12,7

NEW!!

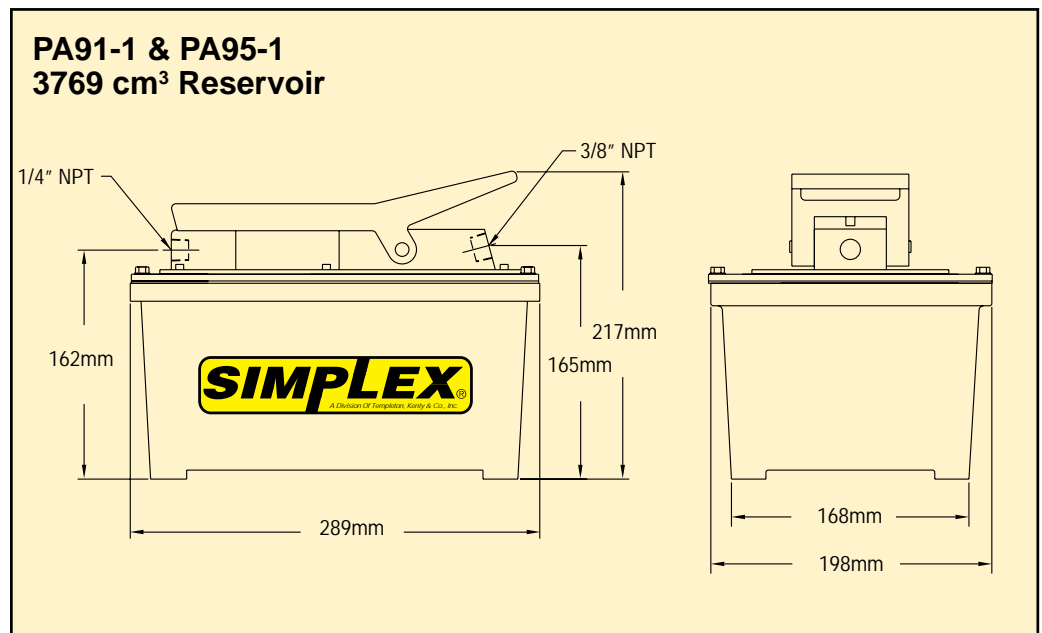
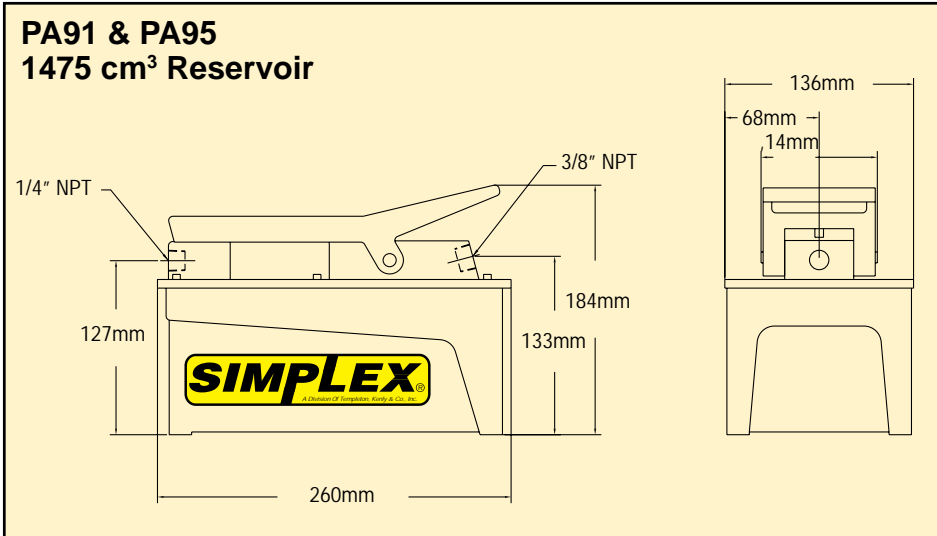

When reliable 700 bar power was needed to run this production line fixture, industrial engineers chose the Simplex PA91. "The three position treadle is easy to use and the pump runs on standard shop air."