

J5 - 5 TON

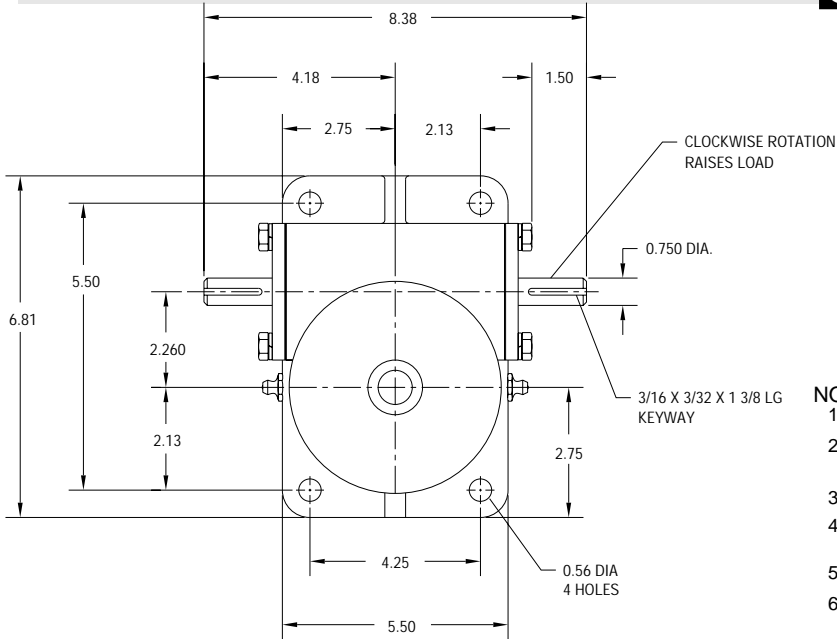

REF.	GEAR RATIO	TURNS /INCH	TORQUE REQUIRED TO LIFT 1 LB (lb-in)
L	5 1/3:1	16	0.042
M	12:1	36	0.027
H	24:1	72	0.019
RATED CAPACITY			10,000 lbs.
Max Input Speed			1725 rpm
Max Screw Stock			228 in.
Load Screw			1 1/2 in. dia. x .333 in. lead
Stop Nut Allowance			1 in.

NOTES:

1. Load screw or nut must be secured to produce linear travel.
2. Dimensions are for reference only and will change with the addition of boots, attachments, and accessories.
3. Boots and boot adaptors are available. (Pages 74-75)
4. Travel must be adjusted to allow for mounting structure on inverted actuators.
5. Customer is responsible for providing positive stops at ends of travel.
6. **KEYED JACKS: ADD 9/16 INCHES TO JACK HOUSING.**

UPRIGHT J-5-U-T

TRANSLATING & KEYED

INVERTED J-5-I-T

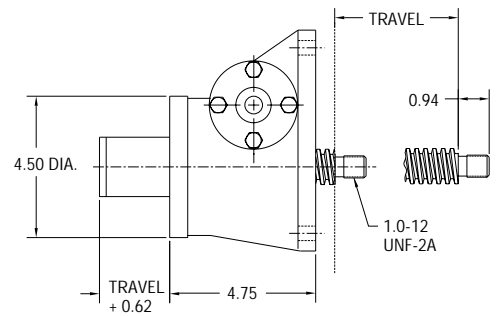
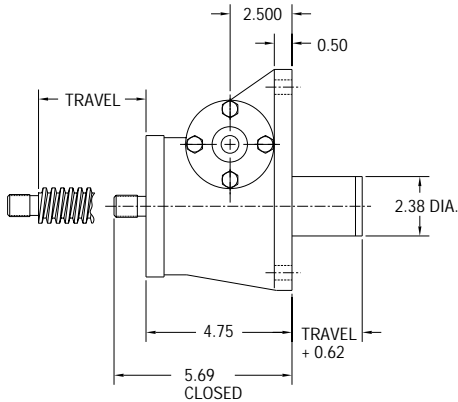

TOP PLATE AND CLEVIS END OPTIONS

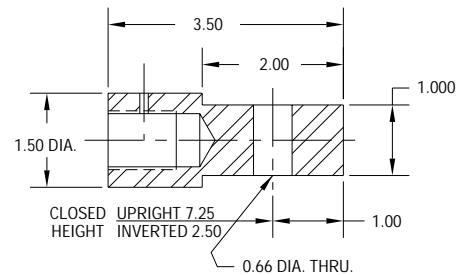
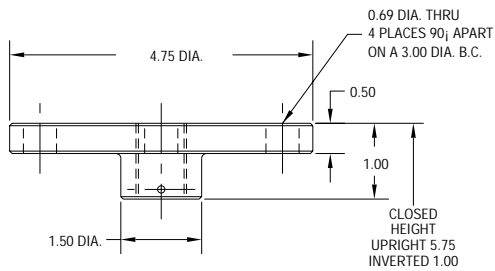

UPRIGHT J-5-U-R

ROTATING WITH TRAVELING NUT

INVERTED J-5-I-R

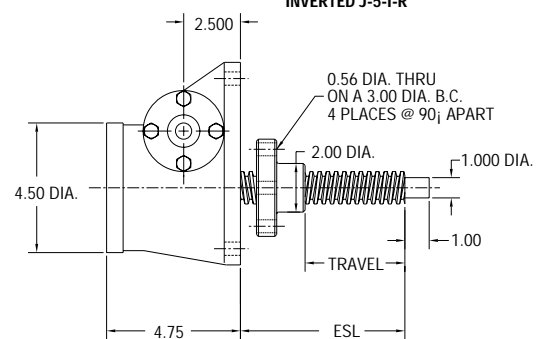
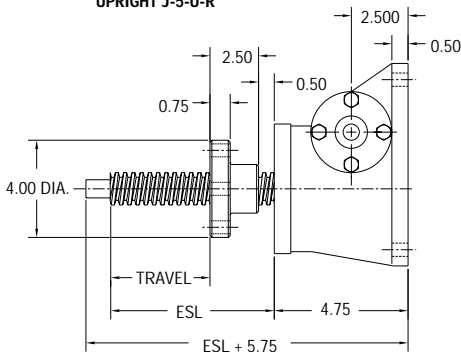

TRAVEL NUT POSITION A

TRAVEL NUT POSITION B