

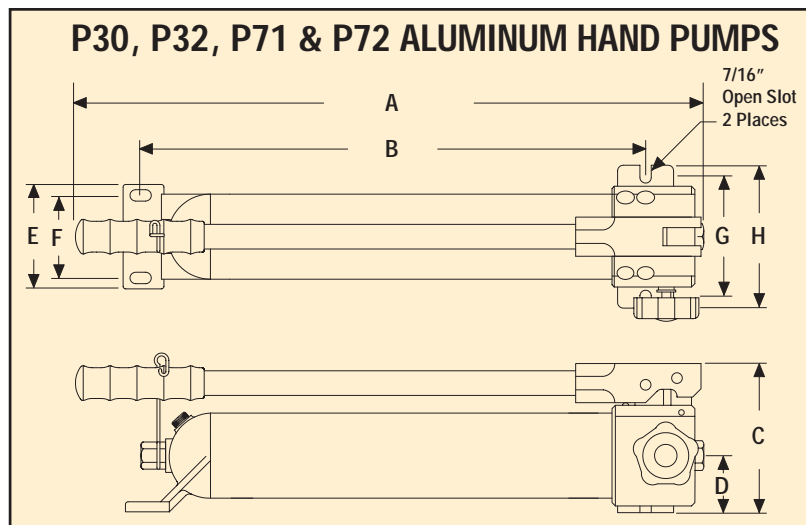

- 5 standard models in 30 and 70 cu. in. reservoir capacity.
- P30 is ideal for low pressure applications when a small light weight pump is required.
- Lever bar fastens for use as carrying handle.
- 25% faster per stroke than comparative pumps means less work for the operator.
- Low handle effort for easy operation.
- All alloy construction resists corrosion.
- 3/8" NPTF outlet ports.
- Complies with ANSI/ASME B30.1 safety standards.
- Weighing just 9 lbs. with a full 70 cu. in. of usable oil gives the P71 & P72 the highest available capacity at the least amount of weight.



Silver Lite Aluminum Hand Pumps For Single-Acting Cylinders

Model Number	Speed	Pressure Rating (PSI)	Oil Volume Per Stroke (cu. in.)	Usable Oil Capacity (cu. in.)	A (in)	B (in)	C (in)	D (in)	E (in)	F (in)	G (in)	H (in)	Weight (lbs)
P30	2	1 Stage 200	.91	30	16.46	11.81	5.55	2	5.51	4.25	4.56	5.50	8
		2 Stage 3000	.19										
P32	2	1 Stage 200	.43	70	24.09	19.44	5.55	2	5.51	4.25	4.56	5.50	9
		2 Stage 10,000	.06										
P71/P71V*	1	10,000	.14										
P72	2	1 Stage 200	.91	70	24.09	19.44	5.55	2	5.51	4.25	4.56	5.50	9
		2 Stage 10,000	.19										

\*P71V is equipped with Viton seals.