

M1 - 1 TON

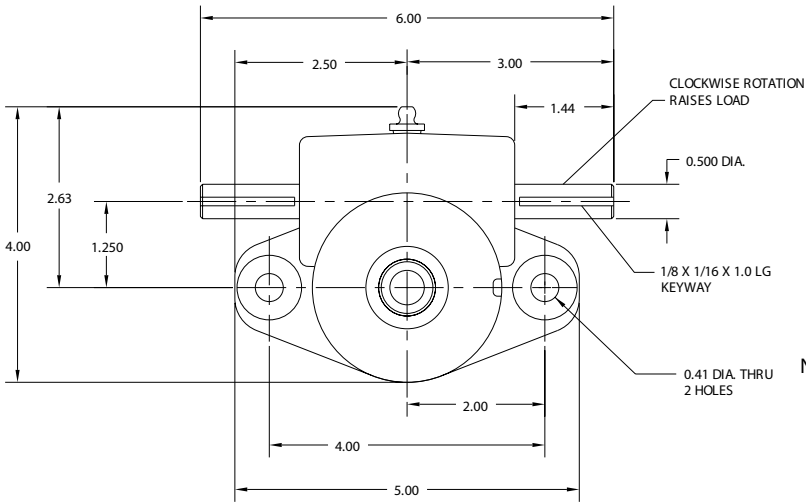

REF.	GEAR RATIO	TURNS /INCH	TORQUE REQUIRED TO LIFT 1 LB (lb-in)
L	5:1	25	0.024
H	20:1	100	0.011
RATED CAPACITY			2,000 lbs.
Max Input Speed			1800 rpm
Max Screw Stock			230 in.
Load Screw			.75 in. dia. x .200 in. lead
Stop Nut Allowance			.75 in.

NOTES :

1. Load screw or nut must be secured to produce linear travel.
2. Dimensions are for reference only and will change with the addition of boots, attachments, and accessories.
3. Boots and boot adaptors are available. (Pages 74-75)
4. Travel must be adjusted to allow for mounting structure on inverted actuators.
5. Customer is responsible for providing positive stops at ends of travel.
6. KEYED JACKS: ADD .057 INCHES TO JACK HOUSING.

TRANSLATING & KEYED

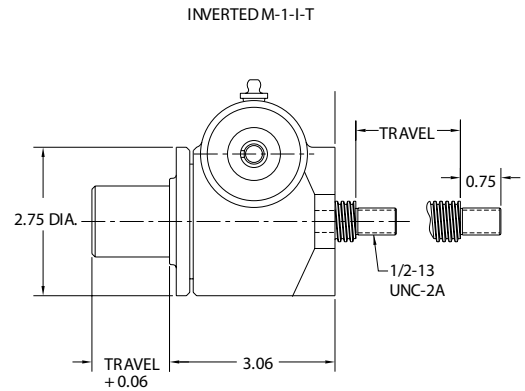
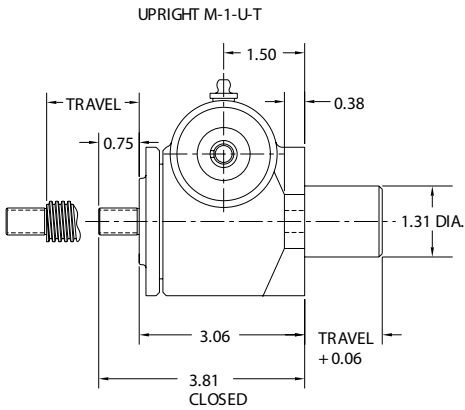

TOP PLATE AND CLEVIS END OPTIONS

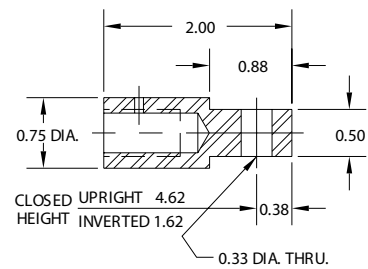
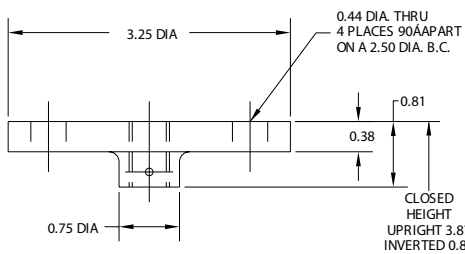

ROTATING WITH TRAVELING NUT

