

HYDRAULIC TOOLS

NUT SPLITTERS

- 7 different models.
- Cuts hardened nuts up to grade 8 & 2H.
- Safety, no sparks, no flame, no impact.
- Replacement chisel and set screws included.
- Cuts any shape nut.
- Cuts nuts from 1/2" to 2 15/16" (13 to 75mm).
- Rugged carrying case included.
- Broadest Range / Best Value.
- Angled head design for easy placement on nut.



Refineries, steel mills and power plants rely heavily on Simplex nut splitters for removing stubborn or rusted nuts easily and safely. The Simplex nut splitters offer a wide range of sizes at exceptional values.

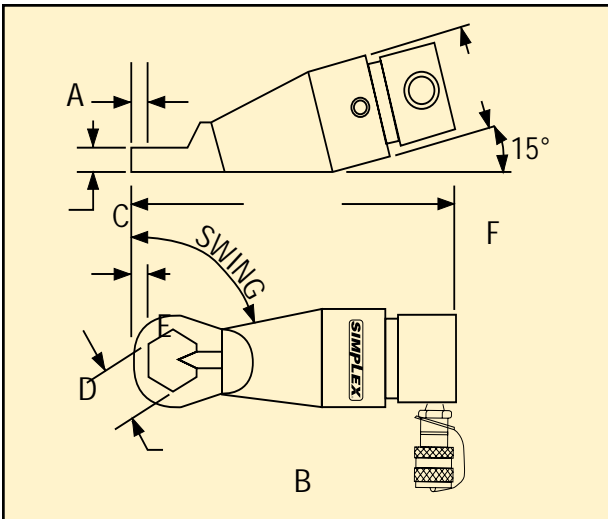

Hydraulic Nut Splitters

Model Number	Stud Dia. (mm)	Nut A/F (in.)	Nut A/F Metric (mm)	A (mm)	B (mm)	C (mm)	D (mm)	E (mm)	F (mm)	Weight (kg)	Sugstd. Hand Pump
NS1319	6 - 11	1/2 - 3/4	13 - 19	40	200	6	19	28	48	0,8	P42
NS1924	11 - 14	3/4 - 15/16	19 - 24	55	227	8	25	38	71	2,0	
NS2432	14 - 19	15/16 - 1 1/4	24 - 32	66	260	10	31	49	76	3,0	
NS3241	19 - 25	1 1/4 - 1 5/8	32 - 41	75	286	15	35	66	89	4,4	
NS4150	25 - 32	1 5/8 - 2	41 - 50	96	325	21	45	73	109	8,2	P140
NS5060	32 - 38	2 - 2 3/8	50 - 60	106	366	27	54	126	126	11,8	
NS6075	38 - 48	2 3/8 - 2 15/16	60 - 75	156	367	27	75	110	180	34,1	