

## SIMPLEX STEAMBOAT JACK

These 20 ton capacity models are used for connecting river barges, pulling forms and steel plates together and other applications in bridge construction and concrete and steel engineering projects. Units are equipped with spring activated pawls and 660mm long attached handles. The handle effort per ton is 7,3kg. The I.D. of the eye is 33mm. Depth of eye is 48mm.

Model Number	Dim. "A" (mm)	Travel (mm)	Barrel Length (mm)	Screw Dia. (mm)	Weight (kg)
ER-10	584	356	457	51	25,9
ER-20	737	508	610		30,0
ER-30	889	660	762		33,6
ER-40	1194	965	1067		41,8

## SIMPLEX 610 PUSH/PULL JACK

The model 610 is used for pushing or pulling, holding & more; **ideal for weld shops.**

For added versatility, the end nuts are designed to permit the use of chains with eye hooks. Steel lever bar is ordered separately.

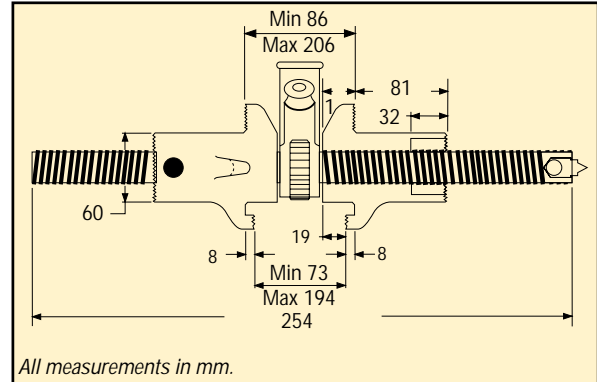

## SIMPLEX 610-15 RATCHET SCREW ASSEMBLY

The ratchet screw assembly may be custom adapted to almost any push/pull application such as adjusting forms, fixtures, doors, flues, and dampers. Incorporates 1 1/4-6 Acme class 2G, right and left hand thread.



Model Number	Centered Capacity (tons)	Hook/Toe Offset Load Capacity (tons)	Travel (mm)	Handle Effort Per Ton (kg)	Screw Dia. (mm)	Length (mm)	Weight (kg)	Steel Lever Bars			
								Order Number	Length (mm)	Dia (mm)	Weight (kg)
610	10	2	114	6,8	32	254	5,9	10621	610	19	1,8
610-15	10	2	----	6,8	32	----	2,3				