

50 - 150 TON ALUMINUM LOCKNUT CYLINDERS

Simplex Silver Lite Aluminum Cylinders Cut Carrying Weights Up To 60%.

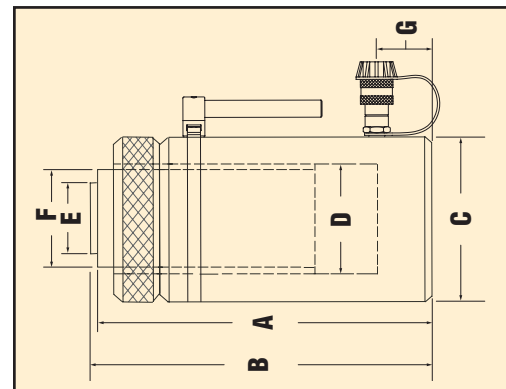

- 11 standard models from 50 through 150 tons.
- Locknuts for extended load holding.
- Large bearing surfaces for side load protection.
- Hard anodized coating reduces wear & corrosion.
- Carry handles standard on all models.
- Stop ring for piston blow-out protection.
- Heavy duty spring for fast & full retraction.
- High flow quality couplers.
- Complies with ANSI/ASME B30.1 safety standards.



Aluminum Lock Nut Spring Return Cylinders 50 Through 150 Ton Capacities

Model Number	Cap. (tons)	A Stroke (in)	B Min. Ht. (in)	Ext. Ht. (in)	Effect Area (sq in)	Oil Cap. Req'd (cu in)	C Body O.D. (in)	D Cyl. Bore Dia. (in)	E Saddle Dia. (in)	F Piston O.D. (in)	G Base To Port C/L (in)	Weight (lbs)	Sugstd. Hand Pumps
RAL502	50	2	8.125	10.125	11.04	21.65	5.5	3.75	2.50	3.125	1.5	22	P42/P72
RAL504		4	10.125	14.125		43.30						38	P72/P82
RAL506		6	12.125	18.125		64.92						32	P72/P82
RAL5010		10	16.125	26.125		108.20						40	P140
RAL1002	100	2	8.375	10.375	20.68	40.51	8	5.125	3.5	4.25	1.5	45	P72/P82
RAL1004		4	10.375	14.375		81.00						55	P82
RAL1006		6	12.375	18.375		121.50						64	P140
RAL10010		10	16.375	26.375		202.50						82	*
RAL1502	150	2	8.375	10.375	30.68	60.60	10	6.25	4.5	5	1.5	65	P140
RAL1506		6	12.375	18.375		181.80						101	*
RAL15010		10	16.375	26.375		303.00						156	*

*Power pumps are suggested for these units (see pages 44-62).

CUSTOM STROKES AND CAPACITIES AVAILABLE, CONTACT FACTORY