

# CYLINDERS



## LOAD RETURN - 30-1000 TON

*Simplex Cylinders Provided The Power & Reliability To Rearrange Our Shop Floor In One Day.*



The problem was to reposition machine centers without disrupting production. "Using Simplex RLR Series cylinders and a PE70 series **Suc-O-Matic** pump, we rearranged our shop floor in one day." The low closed height and longer strokes eliminated extra jacking & blocking procedures, and the Simplex Suc-O-Matic retracted load return cylinders effortlessly.

- 31 Models
- Rated for full duty.
- High flow quality couplers.
- Low closed heights.
- Plated pistons to resist scoring & corrosion.
- Stop rings for piston blow-out protection.
- Large bearings resist side load.
- Available in custom strokes & capacities.
- Rod wiper protects inner cylinder from dirt.
- Domed pistons on 150 to 1,000 ton capacities help resist side load.
- 9° Swivel on 30 to 100 ton capacity load caps for side load protection.
- Exceeds ANSI/ASME B30.1 safety standards.
- Optional swivel load caps are available for 150 through 1,000 ton models.
- Removable swivel lifting eyes on 100 through 1,000 ton models.

		
Power Pumps pgs. 40-58	Hoses pgs. 66-67	Couplers pg. 64 Manifolds & Fittings pg. 65



When railcar bulk heads need straightening, a 150 ton Simplex cylinder used with a SUC-O-MATIC™ power pump can save the day. Simplex load return cylinders completely retract in any position when used with the Simplex SUC-O-MATIC™ power pumps.



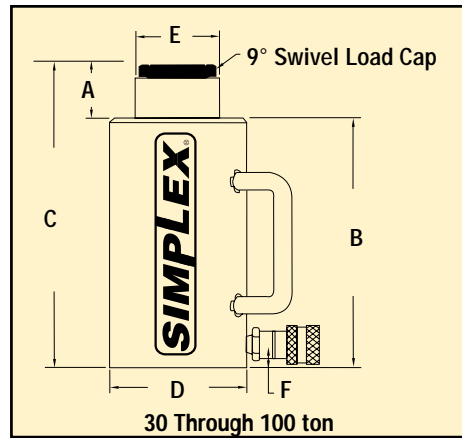

Note: 100 ton models have removable lifting eye bolts in lieu of carrying handles.

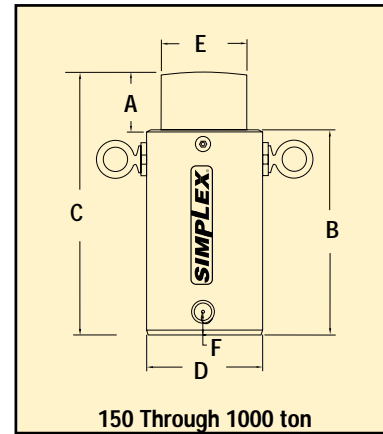

Note: Eye bolts are removable.

## Load Return Jacking Cylinders 30 Through 1000 Ton Capacities

Model Number	Cap. (tons)	A Stroke (mm)	B Min. Ht. (mm)	C Ext. Ht. (mm)	Ram Bore Dia. (mm)	Effect Area (cm <sup>2</sup> )	Pres. @ Cap. (bar)	Oil Cap. Req'd (cm <sup>3</sup> )	D Body O.D. (mm)	E Piston O.D. (mm)	F Base To Port C/L (mm)	Weight (kg)	Suggested Power Pump
RLR306	30	152	238	391	73	14,9	637,6	637,6	102	51	19	14,5	Simplex Suc-O-Matic™ equipped Power Pumps are highly recommended to power load return cylinders. Unlike any other power unit, Simplex Suc-O-Matic™ equipped Pumps will fully retract load return cylinders automatically.  For more information on the Suc-O-Matic™ feature see pages 40 - 58.
RLR502	50	51	138	189	95	71,3	624,7	362,6	140	76	20	13,6	
RLR506		152	240	392				1086,7				25	
RLR5010		254	341	595				2179,9				41,8	
RLR1002	100	51	167	217	127	126,7	700	655,6	162	86	32	27,3	
RLR1006		152	271	421				1934				52,3	
RLR10010		254	370	624				3212,4				83,6	
RLR1502	150	51	178	229	159	197,9	674,7	1088,3	229	141	49	53,2	
RLR1506		152	279	432				3261,6				85,9	
RLR15012		305	432	737				6523,2				135	
RLR2002	200	51	203	254	184	266,3	624,7	1448,9	254	167	52	83,6	
RLR2006		152	305	547				4343,3				128,2	
RLR20012		305	457	762				8686,7				195	
RLR3002	300	51	298	349	222	388	688,5	1966,8	305	198	62	125,9	
RLR3006		152	349	502				5916,8				184,1	
RLR30012		305	502	806				11834				271,3	
RLR4002	400	51	300	300	267	558,7	637,4	2851,9	356	237	52	206,8	
RLR4006		152	402	554				8522,8				278,2	
RLR40012		305	554	859				17046				382,7	
RLR5002	500	51	321	371	292	670,2	664,3	3409,1	406	262	81	285	
RLR5006		152	422	575				10211				388,6	
RLR50012		305	575	879				20422				544	
RLR6002	600	51	343	394	318	791,7	674,7	4031,9	444	287	52	297,7	
RLR6006		152	444	597				12092				410	
RLR60012		305	597	902				24192				578,6	
RLR8002	800	51	367	418	368	1065,4	688,6	5408,7	457	338	49	453,1	
RLR8006		152	468	621				16243				570,9	
RLR80012		305	621	926				32485				747,2	
RLR10002	1000	51	410	460	406	1297,2	686,5	6588,8	533	376	52	692,2	
RLR10006		152	511	664				19766				855,8	
RLR100012		305	664	968				39533				1103,3	

CUSTOM STROKES AND CAPACITIES UP TO 1,500 TONS AVAILABLE, CONTACT FACTORY