

SPREADERS 1 - 10 TONS

HYDRAULIC TOOLS

GAT'R JAW™ SPREADERS



- 2 Models
- High flow quality couplers.
- Spring return for easy operation.
- Narrow closed ends.
- All metal construction.

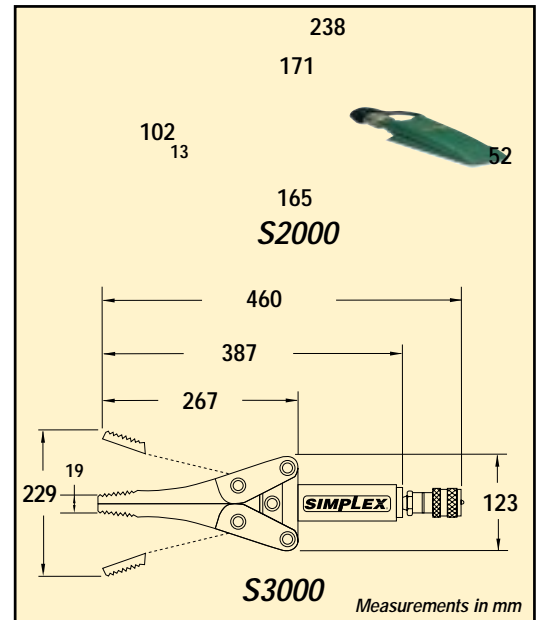

Hydraulic Spreaders 1 & 1 1/2 Ton Capacities

Model Number	Cap. (tons)	Pressure @ Capacity (bar)	Oil Capacity Required (cm ³)	Weight (kg)	Suggested Hand Pump
S2000	1	700	13,1	15,4	P42
S3000	1.5		90,1	35,2	

5 TON HYDRAULIC SPREADER

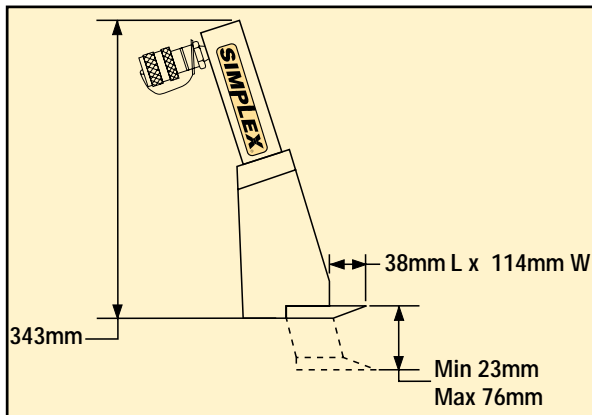

- 5 tons of spreading force.
- 23mm through 76mm spreading capability.
- Jaws open parallel.
- Will not drift.
- All metal construction.



Hydraulic Flange Spreader 5 Ton Capacity

Model Number	Cap. (tons)	Pres. @ Cap. (bar)	Oil Cap. Req. (cm ³)	Weight (kg)	Spread		Suggested Hand Pump
					Min. (mm)	Max. (mm)	
SF5	5	700	81,9	37,4	23	76	P22

10 TON SPREADER/PULLER



Mechanical Spreader/Puller 10 Ton Capacity

Model Number	Cap. (tons)	Offset Cap. (tons)	Travel (mm)	Screw Dia. (mm)	Length (mm)	Wt. (kg)	Steel Lever Bars			
							Order Number	Length (mm)	Dia (mm)	Wgt. (kg)
610	10	2	114	32	254	28,6	10621	610	19	8,8

